

ARTÍCULO  
 Item/Article

**M4002C**

- Monomando baño/ducha MEGAN, cartucho 25mm
- Single-lever bath/shower mixer MEGAN, cartridge 25mm
- Mitigeur baignoire/douche MEGAN, cartouche 25mm

**SERIE: MEGAN**

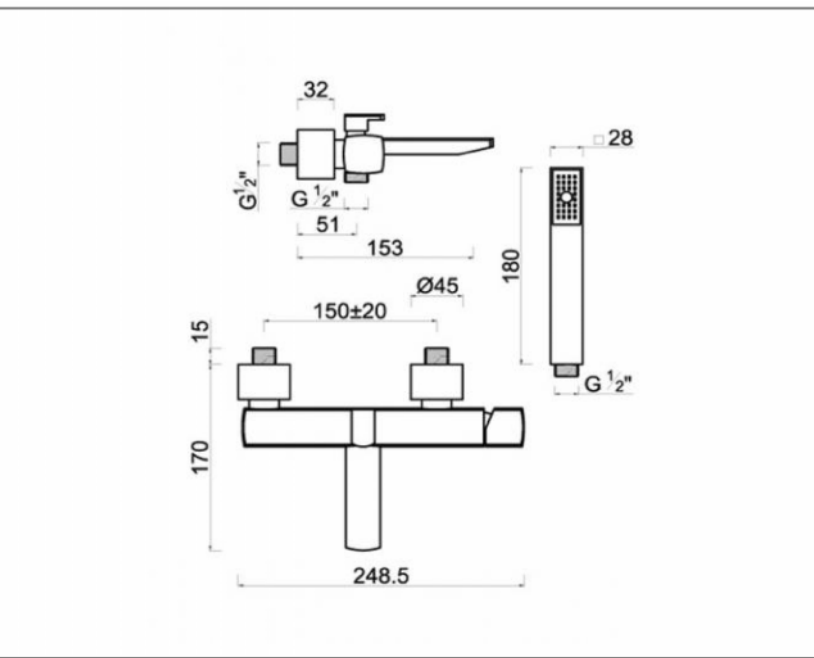

CARACTERÍSTICAS FUNCIONALES	OPERATING CHARACTERISTICS	CARACTÉRISTIQUES FUNCTIONNELLES
Cartucho con discos cerámicos 25mm Desviador automático: baño/ducha Caudal a 3 bar: aprox. 19 l/min Cromado de alta calidad Mango de ducha anticalcáreo Flexo metalico 1.70m Soporte de ducha cónico Excentricas (150+-20)	Cartridge with ceramique discs 25mm Automatic deviator: bath/shower Flow rate at 3 bar: approx. 19 l/min Chrome finish high quality Hand shower anti-scale Hose matallic 1.70m Hand shower support Excentrics (150+-20)	Cartouche disques en céramique 25mm Sélecteur: baignoire/douche Débit à une pression dynamique de 3 bar: env. 19 l/min Chromage haute qualité Douche à main anti calcaire Flexo métalllic 1.70m Support pour douche Excentriques (150+-20)